

ETS Inc. SMDA8 Distribution Amplifier Instructions

The SMDA8 is a 8 channel active “signal splitter”. It is designed to power up any SM1 series microphone and distributes the audio signal to up to 8 DVRs, I/P cameras, etc.

SM1 Microphone Placement

Locate the SM1 microphone as close as possible to the area of interest in the space to be monitored. Do not mount the microphone near air conditioning vents, light fixtures or electrical equipment. The SM1s should be placed at least 5 feet away from the subject(s) to be monitored. An SM1 is still useable in the range of 15-25 feet but is dependent on the level of background noise in the area. Experimentation in the environment will determine what distances work best.

SMDA8 location and power

The SMDA8 interface box is designed to be located next to a DVR or I/P camera. The SMDA8 requires a 120VAC power source within 3 feet of its location. If this is not possible in your application, you can splice in up to 100 feet of 18 awg, 2 conductor cable to extend the distance between the AC power source and the SMDA8.

Cable Run

Run a 22 gauge, stranded, two conductor shielded cable between the SMDA8 amplifier and the SM1 microphone. Keep the cable run distance under 1,000 feet and away from AC power sources, light fixtures and electrical equipment. *See Figure 1 for connection diagram.*

SMDA8 Inputs

The input to the SMDA8 can be connected directly to any Sound Surveillance microphone or any other “line level” input signal (“AUX” input). Use one input type only. Do not use both inputs at the same time.

SDA4 level controls

The overall input level is controlled with the Master level control. This control provides x2 gain for weaker input signals or attenuation for stronger signals. The Master level controls the volume of audio that is fed into each channel output. Each audio output level can also be individually adjusted. This is useful if some “head end” equipment is more or less sensitive to larger or smaller signal levels. Experimentation will determine what positions are appropriate.

SMDA8 audio outputs

These outputs are typically connected to the audio inputs of DVRs, I/P cameras, etc. You can extend these outputs up to 1000 feet using audio coaxial cable and field installable RCA (or 3.5mm) connectors. These outputs can be connected to any ETS base station microphone input. Cut one end off the supplied patch cable. Strip the cable back and connect the center conductor of the coax to the “audio” terminal and the shield to the “-” terminal of any microphone input. No connection is needed on the “+” terminal.

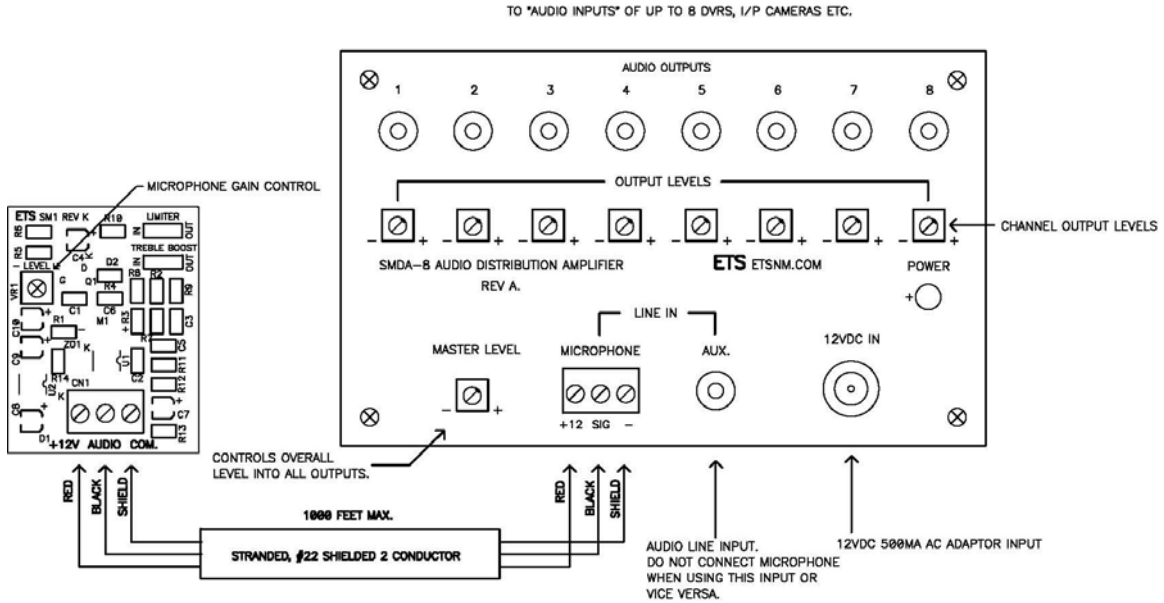

Figure 1.

Caution

It may be against the law to install this microphone kit in certain environments. It may also be against the law to record conversations of the person(s) being monitored without their knowledge. It is the responsibility of the installation company and end-user to determine if the application of this product is legal. These laws vary from state to state. If you are not informed on these matters, consult a qualified attorney or contact the appropriate state agency. A sticker is provided with this kit for the applications where notification must be posted.

Warranty

All ETS products carry a one year parts and labor warranty. This warranty does not cover damages as a result of misuse, improper handling of the unit or exposure to extreme temperatures or moisture. At its discretion, ETS reserves the right to repair or replace this unit under the conditions of the warranty. If you experience problems with your equipment call ETS at: 505-888-3923 to obtain a return authorization number. Equipment requiring repair beyond the warranty period or units that have been damaged or are not covered under the warranty can be repaired by ETS for a minimal cost under most conditions.

Made in the USA
by
ETS Inc.