

ETS Inc. SMEQ-1 Eq. / interface Instructions

The SMEQ-1 is a single channel audio equalizer and microphone interface. It is designed to connect directly to any SM1 series microphone and a DRV, I/P camera, etc or any ETS base station or interface box etc. Note- the audio output of the SMEQ-1 is "line level" (0db).

SM1 Microphone Placement

Locate the SM1 microphone as close as possible to the area of interest in the space to be monitored. Do not mount the microphone near air conditioning vents, light fixtures or electrical equipment. The SM1 should be placed at least 5 feet away from the subject(s) to be monitored. An SM1 is still useable in the range of 15-25 feet but is dependent on the level of background noise in the area. Experimentation in the environment will determine what distances work best.

SMEQ-1 location and power

The SMEQ-1 interface box is designed to be used as a stand alone DVR or I/P camera interface or it can be used "in line" with any ETS base station. When used as a DVR or I/P camera interface, use the supplied AC adaptor. When the SMEQ-1 is used with an ETS base station, The AC adaptor is not required because it draws power from the ETS base station.

Cable Runs

Run a 22 gauge, stranded, two conductor shielded cable between the SMEQ-1 module and the SM1 microphone and the SMEQ-1, and ETS base station or interface box. Keep the cable run distances under 1,000 feet and away from AC power sources, light fixtures and electrical equipment. *See Figure 1 for connection diagram.*

Audio input

Connect any SM1 series microphone to the microphone input OR any other "line level" signal to the audio input. Do not use both inputs at the same time.

SMEQ-1 audio output

This output is typically connected to the audio input of the DVR, I/P camera, etc. The output level can be adjusted to match the sensitivity of your equipment but, this control set to mid-point should be adequate in most applications.

Setting the SMEQ-1 levels.

Setting an equalizer for the desired overall sound is a subjective topic. Experimenting with the controls is the best way to learn and achieve good results. We recommend using headphones to evaluate the sound quality. Start with setting all controls to the mid-point (flat= no gain or cut). We suggest you do this when the desired sound source is present (people taking, being interviewed, etc.) Adjust each control clockwise and counter clockwise to get a feel for how each band affects the overall sound. Keep in mind that the human voice resides in the 1Khz-6Khz range. To focus on these bands the 60Hz, 150Hz, 400Hz and 10Khz controls can all be turned full counter clockwise. The remaining 3 controls (1Khz, 2.5Khz and 6Khz) can then be adjusted for best sound clarity and intelligibility. Note- turning any of the controls fully clockwise will produce noticeable amplifier noise (a hissing sound).

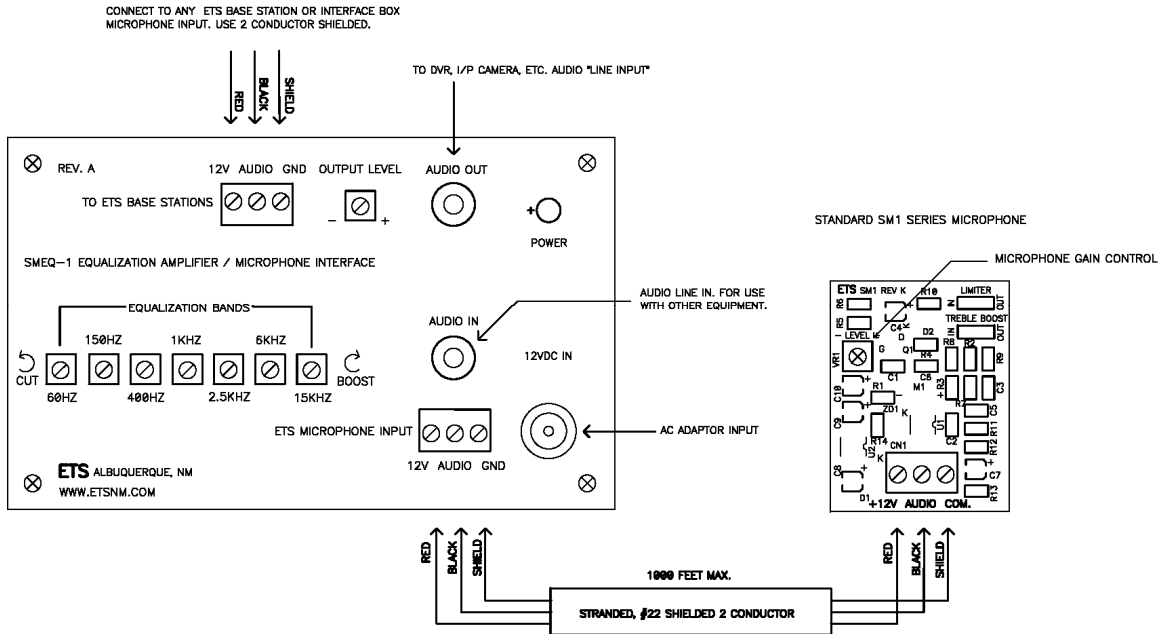

Figure 1.

Caution

It may be against the law to install this microphone kit in certain environments. It may also be against the law to record conversations of the person(s) being monitored without their knowledge. It is the responsibility of the installation company and end-user to determine if the application of this product is legal. These laws vary from state to state. If you are not informed on these matters, consult a qualified attorney or contact the appropriate state agency. A sticker is provided with this kit for the applications where notification must be posted.

Warranty

All ETS products carry a one year parts and labor warranty. This warranty does not cover damages as a result of misuse, improper handling of the unit or exposure to extreme temperatures or moisture. At its discretion, ETS reserves the right to repair or replace this unit under the conditions of the warranty. If you experience problems with your equipment call ETS at: 505-888-3923 to obtain a return authorization number. Equipment requiring repair beyond the warranty period or units that have been damaged or are not covered under the warranty can be repaired by ETS for a minimal cost under most conditions.

Made in the USA
by
ETS Inc.