

The STW1 is a two-way audio surveillance system (intercom accessory) designed to be used with DVRs, I/P cameras etc. Note- STW1s are not recommended for outdoor use where they may be exposed to water.

STW1 Microphone / Speaker Placement.

Locate the STW1 as close as possible to the area of interest in the space to be monitored. If a large area is to be monitored, locate the STW1 in the middle of the space if possible. Do not mount the STW1 near air conditioning vents, light fixtures or electrical equipment. The STW1 operates optimally at a distance of 3-5 feet from the subject(s) to be monitored. The STW1 is still useable in the range of 15-25 feet but is dependent on the level of background noise in the area. Experimentation in the environment will determine what distances work best.

Cable Runs

Run 2 each 22 gauge, stranded, two conductor shielded cable between the STW1 microphone / speaker and the interface equipment. Keep both cable run distances under 250 feet and away from AC power sources, light fixtures and electrical equipment. See *connection diagrams below*.

Mounting

To flush mount the STW1 on ceilings or walls, cut a 3.5" x 2.25" rectangular hole in the wall or ceiling tile to allow room for the circuit board and mount the STW1 to the surface with screws. The STW1 can also be mounted on a double gang electrical box.

STW1 Optional Call Switch

Connect this switch (STW1 terminals cs1 and cs2) to equipment that permits a "page" signal input. It is a N.O. (normally open) dry switch contact. Use a 22awg 2 conductor for this cable run.

Speaker Line / 70v switch

If you are using a "line level" (0db) audio signal input for the speaker, make connections as shown in the first drawing below and place the input switch in the "line" position. If you are using a "70v" audio input for the speaker, make connections as shown in second drawing below and place the input switch in the "70v" position.

Adjusting the STW1 Speaker Gain and Speaker Volume

Begin with a midrange setting of the gain control on the STW1. If it is determined that the speaker volume is too low when the volume is set full clockwise, move the "volume range" jumper to the "HI" position. Then, re-adjust the "SPKR VOLUME" control + or - for maximum microphone clarity. If the sound at the DVR is distorted, rotate the control towards the - mark (counter-clockwise). If the volume at the amplifier is too low, rotate the control towards the + mark (clockwise). Adjust the "talk-back" speaker volume to the appropriate level.

Setting the STW1 Microphone Gain

The STW1 output level is set by selecting the desired volume range and adjusting the gain control.

The "Volume Range" jumper should be set to the "LO" position when using the STW1 with I/P cameras that utilize "microphone inputs" also know as "Mic. Level" inputs. This sets the maximum gain of the STW1's pre-amp to x14. The jumper should be placed in the "HI" position when using I/P cameras with "Line level" inputs of DVRs and I/P cameras. This sets the maximum gain of the STW1's pre-amp to x196.

The STW1 is shipped with the gain set at midrange. If the sound at the "head end" is distorted, rotate the control towards the - mark (counter-clockwise). If the volume at the "head end" is too low, rotate the control towards the + mark (clockwise).

Setting the STW1 Microphone Hi-Cut/Lo-Cut Jumpers

The normal frequency response of the STW1 microphone is 500-13Khz. When both jumpered "in", The "HI Cut" and "Lo Cut" filters set the STW1's frequency response to 900-6Khz. Enabling one or both of the filters is useful when background noise needs to be further reduced and intelligibility of speech emphasized. We recommend experimenting with the jumper settings to achieve the best acoustic result for your application.

INPUT SELECT MUST BE IN "LINE" POSITION FOR USE WITH STWI INTERFACE BOXES

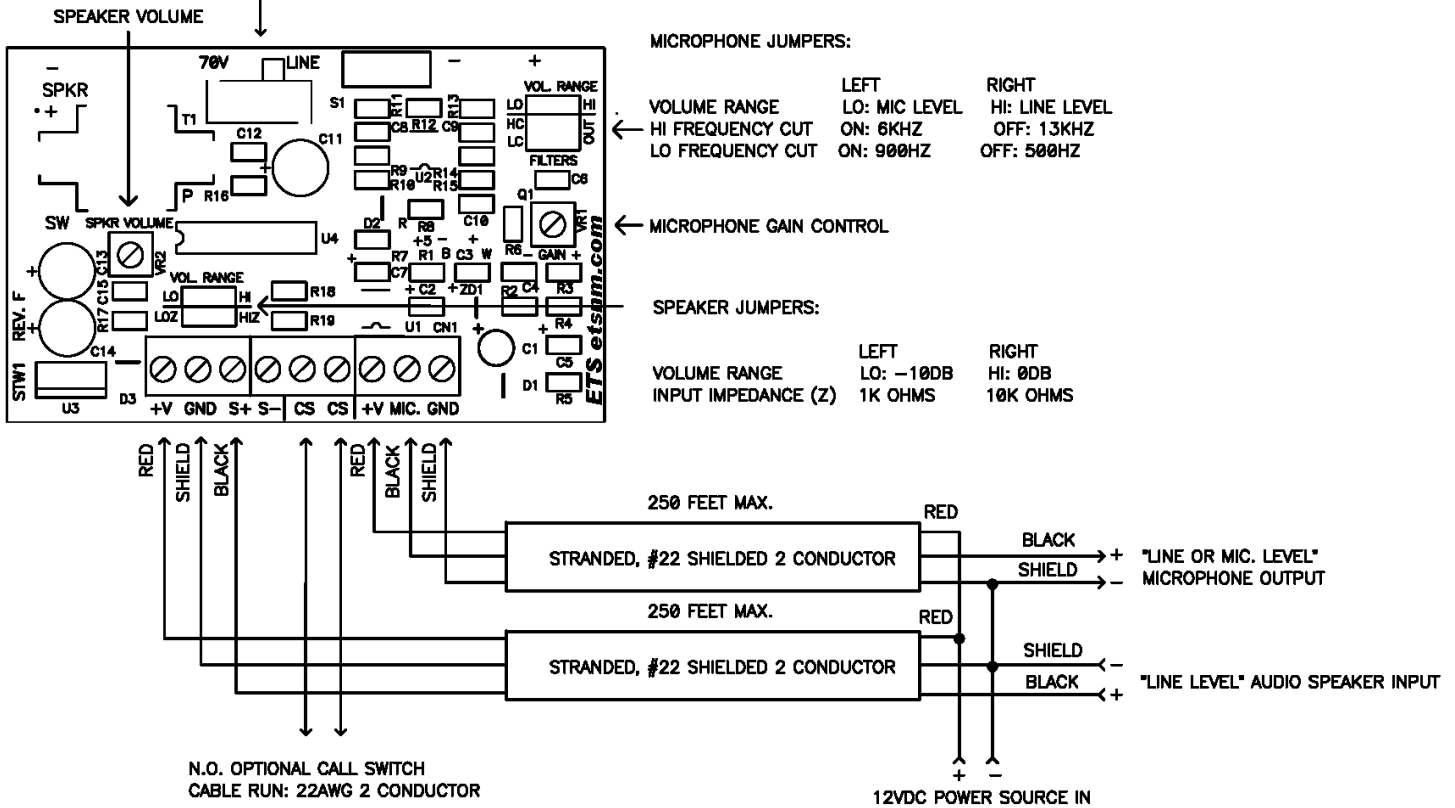

LINE/MIC. MICROPHONE OUTPUT AND LINE LEVEL SPEAKER INPUT

INPUT SELECT MUST BE IN "70V" POSITION FOR USE WITH ETS TWO WAY BASE STATIONS.

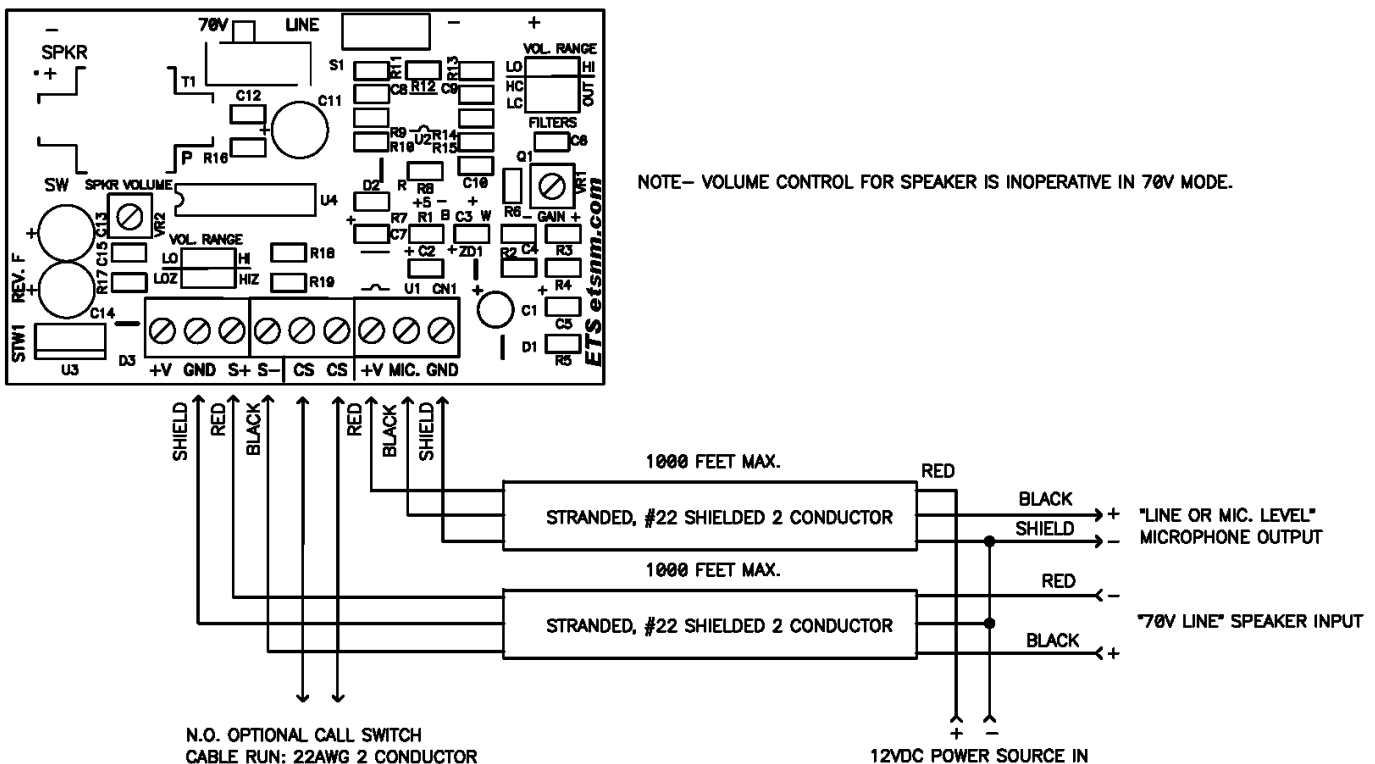

LINE/MIC. LEVEL MICROPHONE OUTPUT AND 70V SPEAKER INPUT

Caution

It may be against the law to install this microphone kit in certain environments. It may also be against the law to record conversations of the person(s) being monitored without their knowledge. It is the responsibility of the installation company and end-user to determine if the application of this product is legal. These laws vary from state to state. If you are not informed on these matters, consult a qualified attorney or contact the appropriate state agency. A sticker is provided with this kit for the applications where notification must be posted.

Warranty

All ETS products carry a one year parts and labor warranty. This warranty does not cover damages as a result of misuse, improper handling of the unit or exposure to extreme temperatures or moisture. At its discretion, ETS reserves the right to repair or replace this unit under the conditions of the warranty. If you experience problems with your equipment call ETS at: 505-888-3923 to obtain a return authorization number. Equipment requiring repair beyond the warranty period or units that have been damaged or are not covered under the warranty can be repaired by ETS for a minimal cost under most conditions.

Made in the USA
by
ETS Inc.